

210D0080 eAir W2-80-60 Datasheet V1-0

Parameter	Unit Einheit	Value / Wert
		400V
Rated air pressure <i>Nennluftdruck</i>	[bar]	12.5
Max. flow rate @ 10 bar <i>Maximaler Volumenstrom @ 10 bar</i>	[l/min]	325
Max. flow rate @ 6.5 bar <i>Maximaler Volumenstrom @ 6.5 bar</i>	[l/min]	360
Rated flow rate @ 10 bar <i>Nennvolumenstrom @ 10 bar</i>	[l/min]	270
Device speed range <i>Drehzahlbereich</i>	[rpm] [1/min]	1000 - 3500
Rated speed <i>Nenn Drehzahl</i>	[rpm] [1/min]	3000
Drive type <i>Antriebstyp</i>	[]	direct <i>direkt</i>
Motor type <i>Motortyp</i>	[]	Permanent Magnet Synchronous Motor <i>Permanenterregter Synchronmotor</i>
Motor output power @ rated speed / 12.5 bar <i>Motornennleistung @ Nenn Drehzahl / 12.5 bar</i>	[kW]	3.6
Motor rated torque @ 12.5 bar <i>Nenn Drehmoment Motor @ 12.5 bar</i>	[Nm]	11.5
Motor rated phase to phase voltage <i>Nennspannung Motor</i>	[V _{RMS}]	400
Motor rated current @ rated speed / 12.5 bar <i>Nennstrom Motor @ Nenn Drehzahl / 12.5 bar</i>	[A _{RMS}]	7.9
Safety valve setup <i>Sicherheitsventileinstellung</i>	[bar]	14
Oil residue <i>Ölrückstände</i>	[ppm]	<3
Oil Quantity <i>Ölmenge</i>	[l]	~1.5
Nominal oil temperature <i>Nenntemperatur Öl</i>	[°C]	70
Maximum oil temperature <i>Max. Öltemperatur</i>	[°C]	105
Nominal air temperature <i>Nenntemperatur Luft</i>	[°C]	<85
Anti-condensing system <i>Kondensatableitung</i>	[]	Automatic <i>automatisch</i>
Noise level @ 2500 rpm <i>Geräuschpegel @ 2500 1/min</i>	[dB(A)]	68

Ambient temperature range* <i>Minimale/Maximale Umgebungstemperatur*</i>	[°C]	-30 / 80
Maximum relative humidity <i>Maximale relative Luftfeuchtigkeit</i>	[%]	85
Protection class <i>Schutzart</i>	[]	IP 67
Base: length / width / height <i>Grundmaße: Länge / Breite / Höhe</i>	[mm]	500 / 320 / 350
Approved compressor oil <i>Zugelassenes Kompressoröl</i>	[]	Acc. DIN ISO 3448 VG46 Nach DIN ISO 3448 VG46
Coolant (air end / motor) <i>Kühlmittel (Kompressor / Motor)</i>	[]	Water/Ethylenglycol 50/50 Wasser/Ethylenglykol 50/50
rated flow rate (motor coolant) <i>Nennvolumenstrom (Motorkühlung)</i>	[l/min]	6
Pressure drop @ rated flow rate / 10 bar <i>Druckverlust @ Nennvolumenstrom / 10 bar</i>	[bar]	0.025
Max. cooling pressure (motor coolant) <i>Maximaler Kühlmitteldruck</i>	[bar]	3
Coolant max temperature <i>Maximale Kühlmitteltemperatur</i>	[°C]	60
Weight <i>Gewicht</i>	[kg]	28.8



* In order to start-up the compressor at ambient temperatures below +3 °C, e.g. after parking the vehicle outside overnight in the winter, the **“Low-Temperature Hardware- and Software solution”** for the compressor is **mandatory** to avoid ice building up inside the compressor.

For normal driving operation, the ambient operating range is -30 °C / +80 °C. When operating the compressor at ambient air temperatures below -15 °C, we recommend using synthetic hydraulic oil.



* Um den Kompressor bei einer Umgebungstemperatur von unter +3 °C starten zu können, ist die Serienmäßig verfügbare **“Niedertemperatur Hardware- und Softwarelösung”** notwendig.

Der eAir V60 W2 ist für Umgebungstemperaturen von -30°C / +80 °C, bei normalen Fahrmanövern, geeignet. Wird der Kompressor bei Umgebungstemperaturen von unter -15°C eingesetzt, empfehlen wir ein synthetisches Hydrauliköl zu verwenden.

Motor MMA 80-8-60-A-...-W2

Parameter	Unit Einheit	Value / Wert
		400 V
Winding type <i>Wicklungsvariante</i>	[]	A
Power <i>Leistung</i>	[kW]	5.2
Torque (rated @ 100°C*) <i>Nenn Drehmoment (@100°C*)</i>	[Nm]	11.5
Torque (rated @ 120°C*) <i>Nenn Drehmoment (@ 120°C*)</i>	[Nm]	16.5
Torque (max @ 100°C*) (60 sec.) <i>Max. Drehmoment (@ 100°C) (60 sec.)</i>	[Nm]	21.5
Torque (max @ 120°C*) (30 sec.) <i>Max. Drehmoment (@ 120°C) (30 sec.)</i>	[Nm]	21.5
Speed (rated) <i>Nenn Drehzahl</i>	[rpm]	3000
Speed (max) <i>Max. Drehzahl</i>	[rpm]	3800
Freq. <i>Freq.</i>	[Hz]	400
Pole pairs <i>Polpaare</i>	[]	8
Current (rated) @ rated torque 120°C <i>Nennstrom @ Nenn Drehmoment 120°C</i>	[A _{RMS}]	11.5
Current (max) @ max torque <i>Max. Strom @ max. Drehmoment</i>	[A _{RMS}]	15.4
Motor voltage (rated phase to phase) <i>Nennphasenspannung Motor</i>	[V _{RMS}]	400
DC-link voltage <i>Zwischenkreisspannung</i>	[V]	>560
Phase:		
k_E	[V _{RMS} /krpm] [V _{RMS} /1000 min ⁻¹]	57
R_{Ph,20}	[Ohm]	0.63
L_d	[mH]	2.7
L_q	[mH]	2.85
Line to line:		
k_{E,LL}	[V _{RMS} /krpm] [V _{RMS} /1000 min ⁻¹]	98.7
R_{LL,20}	[Ohm]	1.26
L_{LL,d}	[mH]	5.4
L_{LL,q}	[mH]	5.7

Connection <i>Verbindung</i>	[]	Y
Moment of inertia <i>Trägheitsmoment</i>	[kgm ²]	0.0020
Weight <i>Gewicht</i>	[kg]	8.6
Protection class <i>Schutzklasse</i>	[]	IP67
Thermal class <i>Wärmeklasse</i>	[]	H
Thermal protection <i>Wärmeschutz</i>	[]	PTC (Pt1000 on request) <i>PTC (Pt1000 auf Anfrage)</i>
Rotational direction** <i>Drehrichtung **</i>	[]	Clockwise <i>rechtsläufig</i>



In order to run the motor, a frequency inverter capable of conducting **sensorless control** for permanent magnet motors is needed, because the motor has no own position sensor or encoder.



* Winding temperature

Performance data were determined with a thermally decoupled engine and a coolant temperature of 60°C at 6 l/min (water/ethylen glycol 50/50)



**The Rotational Direction is defined according to DIN-EN60034-8 (looking on the motor shaft). For the eServo SP12 W2 application the motor has to run counter-clockwise (left) and therefore the rotational direction in the inverter has to be inverted.



Um den Motor in Betrieb nehmen zu können, wird ein Frequenzumrichter benötigt, der eine **sensorlose Steuerung** für Permanentmagnet-Motoren ausführen kann, da der Motor keinen eigenen Positionssensor oder Drehgeber besitzt.



* Wicklungstemperatur

Die Leistungsdaten wurden mit einem thermisch entkoppelten Motor, einer Kühlmitteltemperatur von 60°C bei 6 l/min Volumenstrom (Wasser / Ethylenglykol 50 / 50) bestimmt.



** Die Rotationsrichtung ist nach DIN-EN60034-8 (im Blick auf die Motorwelle) definiert. Für die eServo SP12 W2 Anwendung muss der Motor gegen den Uhrzeigersinn (links) laufen und deshalb muss die Drehrichtung im Wechselrichter umgekehrt werden.

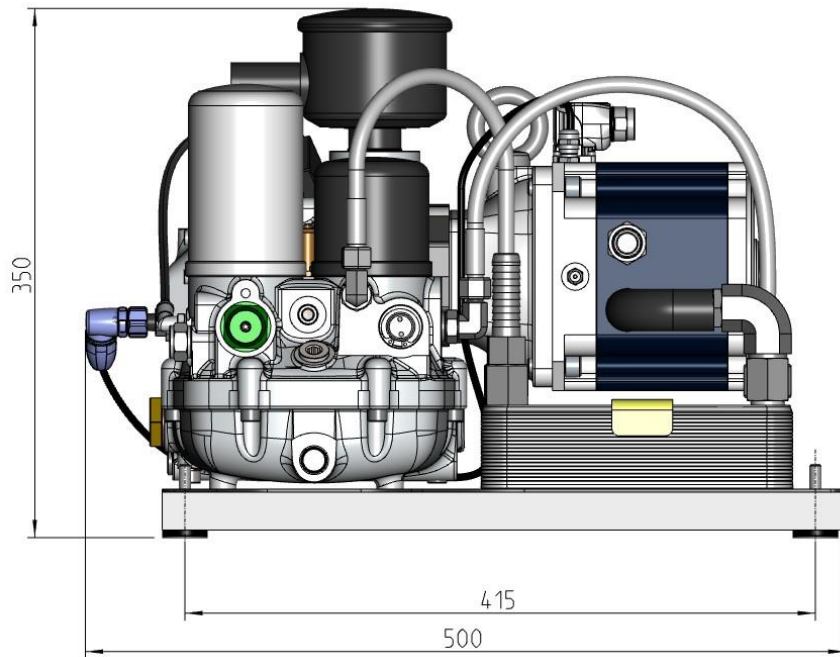

Fig. 1 eAir V60 W2-80-60 Side View
eAir V60 W2-80-60 Seitenansicht

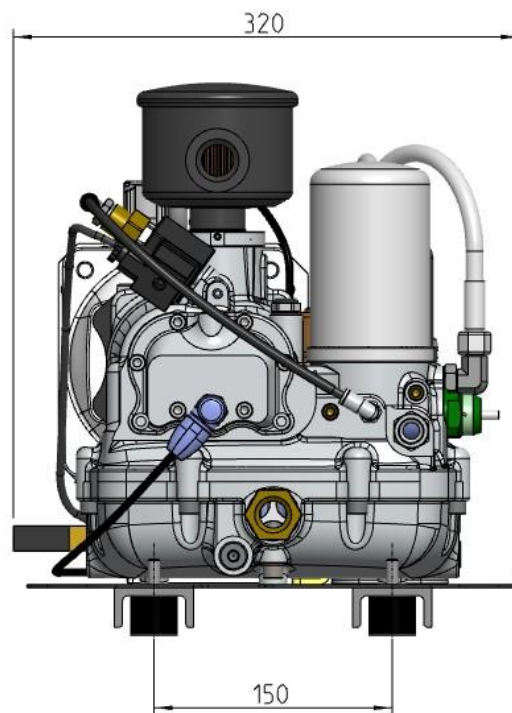

Fig. 2 eAir V60 W2-80-60 Front side
eAir V60 W2-80-60 Vorderansicht